

# 42 SERIES OPERATING INSTRUCTIONS

## Operating Instructions:

1. Insert connector onto test piece. Make sure a minimum of 1.875 (1-7/8") of engagement is achieved. This will ensure proper seal life and gripping ability.



2. Cam the handle 90° from the charge port.



3. Test media can be introduced thru the 1/4" NPT charge port



4. After your test is completed vent the system then remove the connector.

## Adjustment:

1. If the RAMSEAL® connector is not sealing properly some adjustment may be needed.
2. Clockwise to tighten



3. Counterclockwise to loosen.



## Replacement Parts and Assembly Diagram:

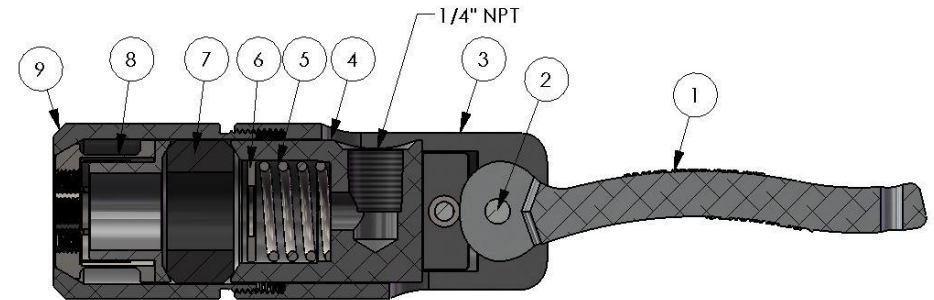

ITEM NO.	PART NO.	DESCRIPTION
1	4202	Handle
2	4203	Handle Pin
3	4201	Body
4	4204	Insert
5	4207	Spring
6	4212-*	Tube Stop (-11 to -14 Only)
7	4208-*	Seal
8	4206-*	Collet
9	4205-*	Head

\* Specify Model Number, and /or Tube I.D. and O.D.