

145-146 SERIES OPERATING INSTRUCTIONS

Operating Instructions:

1. Insert connector onto test piece. Make sure a minimum of .560 of engagement is achieved. This will ensure proper seal life and gripping ability.



2. Cam the handle 90°.



3. Introduce test media through the 1/8" NPT charge port.



4. After your test is completed, vent the system then remove connector.

Adjustment:

1. If the RAMSEAL® connector is not sealing properly some adjustment may be needed.
2. The adjusting nut and body are set using Loctite® from the factory. Uses a 1-1/8" wrench to break the Loctite® loose.
3. Counterclockwise to tighten.



4. Clockwise to loosen.



Replacement Parts and Assembly Diagram:

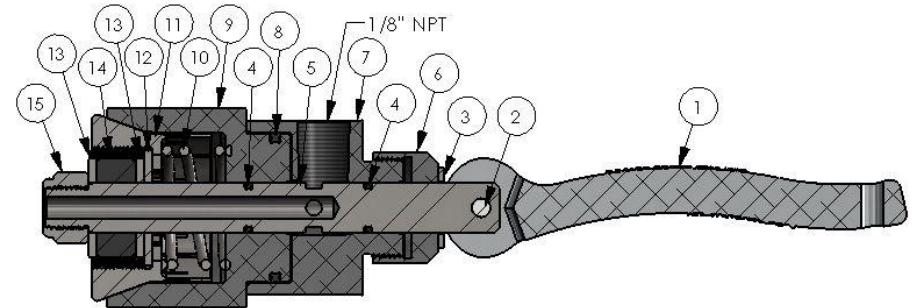

ITEM NO.	MODEL 145	MODEL 146	DESCRIPTION
1	14502	14602	Handle
2	14503	14603	Handle Pin
3	14512	14612	Wear Washer
4	14524	14624	Quad Seal (Shaft)
5	14528	14628	Shaft
6	14531	14631	Adjusting Nut
7	14501	14601	Body
8	14523	14623	Quad Seal (Collet Operator)
9	14522	14622	Collet Operator
10	14507	14607	Spring
11	14506-*	14606-*	Collet
12	14515-*	N/A	Tube Stop
13	14515-*	14615-*	Seal Stop
14	14508-*	14608-*	Seal
15	14517	14617	Seal Stop Nut

* Specify Model Number, and /or Tube I.D. and O.D.